

APPLICATION:

PRODUCT NAME: STAINLESS STEEL
PRE-RINSE 8" C/C BACKSPLASH MOUNT
3/4" FAUCET WITH 14" ADD-ON FAUCET

JOB NAME:

SPECIAL CONFIGURATION
 CHECK BASE MODEL AND OPTIONS

QUANTITY:

ITEM NO.

MODEL:
 24589 WITH WALL BRACKET

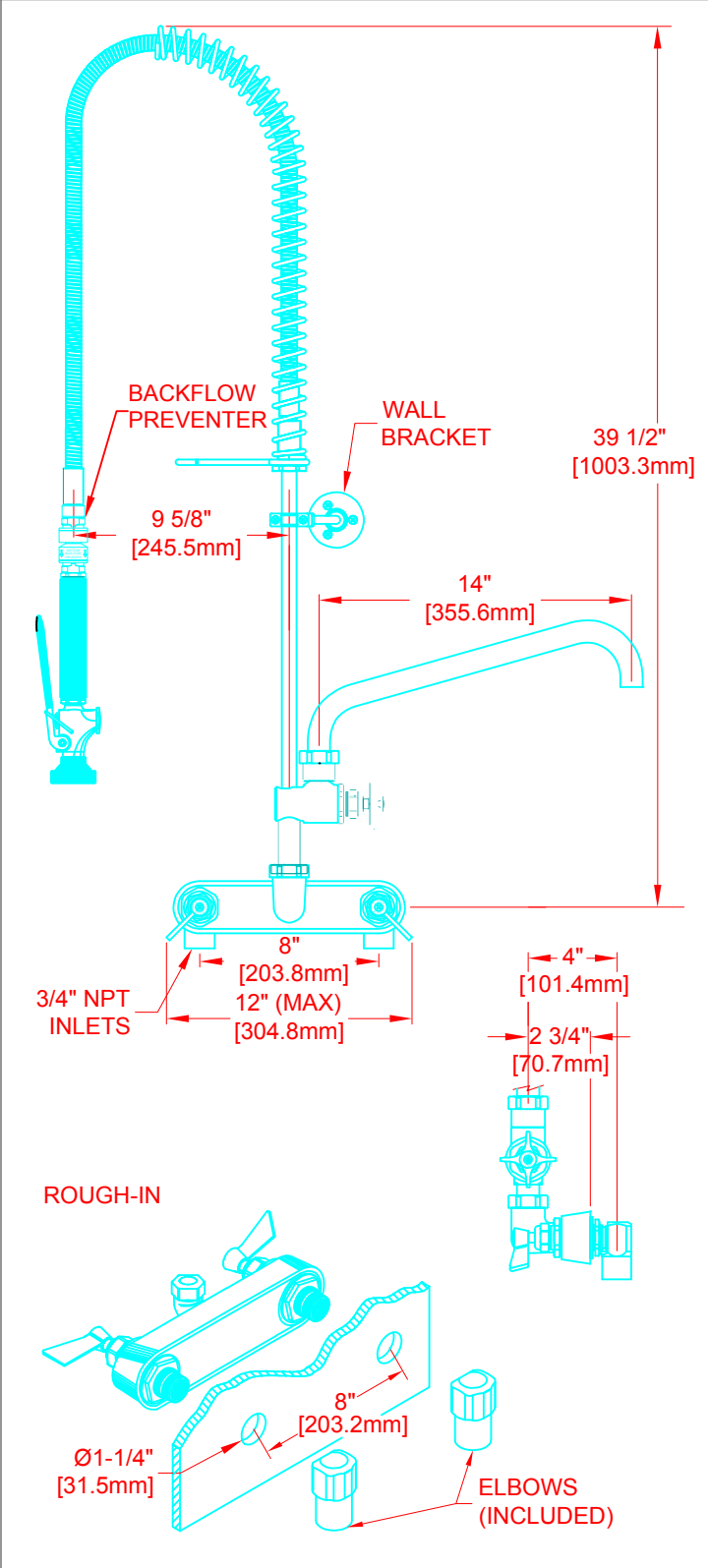

- FEATURES:
- 3/4" MAIN CONTROL VALVE
 - * 8" C/C BACKSPLASH FAUCET
 - * 3/4" NPT INLETS
 - * SWIVELLING SEAT DISKS
 - * HOT SIDE STEM - LEFT HAND
 - * COLD SIDE STEM - RIGHT HAND
 - * STAINLESS STEEL SEATS
 - * STAINLESS STEEL SEAT SCREWS
 - * STAINLESS STEEL HANDLE SCREWS
 - * CLOSE ELBOWS

- ADD-ON FAUCET
- * STEM - RIGHT HAND SWIVEL
 - * COLD INDEX BUTTON
 - * FULL 3/4" SEAT OPENING
 - * SWIVELING SEAT DISKS
 - * STAINLESS STEEL SEATS
 - * STAINLESS STEEL SEAT SCREWS
 - * STAINLESS STEEL HANDLE SCREWS
 - * 14" SPOUT WITH 1" DIAMETER OUTLET
 - * FLOW RATE: 37.0 GPM AT 80 PSI

- HOSE
- * 36" LENGTH
 - * STAINLESS STEEL END FITTINGS
 - * STAINLESS STEEL EXTERNAL JACKET
 - * 3-PLY FIBER REINFORCED INTERNAL RUBBER HOSE

- ULTRA SPRAY VALVE
- * LOWEST ENERGY USER - 1.15 GPM @ 60 PSI
 - * CLEANS FASTER - TEST PROVEN
 - * ENGINEERED TO LAST - NO 'O' RINGS TO LEAK
 - * INTERCHANGEABLE - FITS ALL BRANDS

- WALL BRACKET
- * ADJUSTS FROM 2" TO 12"

- SYSTEM LIMITS
- * TEMP: 40°F MIN. TO 140°F MAX.
 - * PRESSURE 200 PSI MAX. STATIC

- SHIPPING WEIGHT
- * 18.0 LBS

* NSF 61-9 APPROVED & LISTED
www.truesdail.com



FISHER MANUFACTURING COMPANY
TOLL FREE: 800-421-6162 - FAX: 800-832-8238
information@fisher-mfg.com - www.fisher-mfg.com

EPAct 2005 Compliant

ANSI/A112.18.1M