

APPLICATION:

JOB NAME:

QUANTITY:                      ITEM NO.

PRODUCT NAME:

**DrainKing WASTE VALVE**

SPECIAL CONFIGURATION  
CHECK BASE MODEL AND OPTIONS

MODEL:

22446 w/ VANDAL RESISTANT FLAT STRAINER & KNOB OVERFLOW BODY

OPTIONS OR MODIFICATIONS:

SUPPLY LINES (24" OR 36") CIRCLE LENGTH

ADD-ON FAUCET (6", 8", 10", 12", 14", 16") CIRCLE

IN-LINE DUAL CHECK VALVE

HANDLES (CROSS OR WRIST) CIRCLE STYLE

VANDAL RESISTANT KIT

OTHER \_\_\_\_\_

FEATURES:

- \* DUAL TEFLON SEALS
- \* STAINLESS STEEL BALL
- \* CAST RED BRASS BODY
- \* EXTRA SURDY STAINLESS STEEL CLAMPING RING
- \* "CLEAR THROUGH" OPENING, NO NEED TO DISASSEMBLE IF SNAKING IS REQUIRED
- \* INDUSTRY STANDARD "SEALING" ANGLE - FITS FLUSH TO STANDARD STAINLESS STEEL SINKS
- \* VANDAL RESISTANT STAINLESS STEEL FLAT STRAINER
- \* VANDAL RESISTANT KNOB
- \* END CAP W/ GASKET INSTALLED
- \* 1/4 TURN FULLY OPENS AND CLOSES VALVE
- \* SUPPLIED WITH:  
ALTERNATE LEVER HANDLE  
ALTERNATE SLIP JOINT NUT & WASHER

DRAIN RATE:

\* 12 GPM

SHIPPING WEIGHT

\* 5.5 LBS

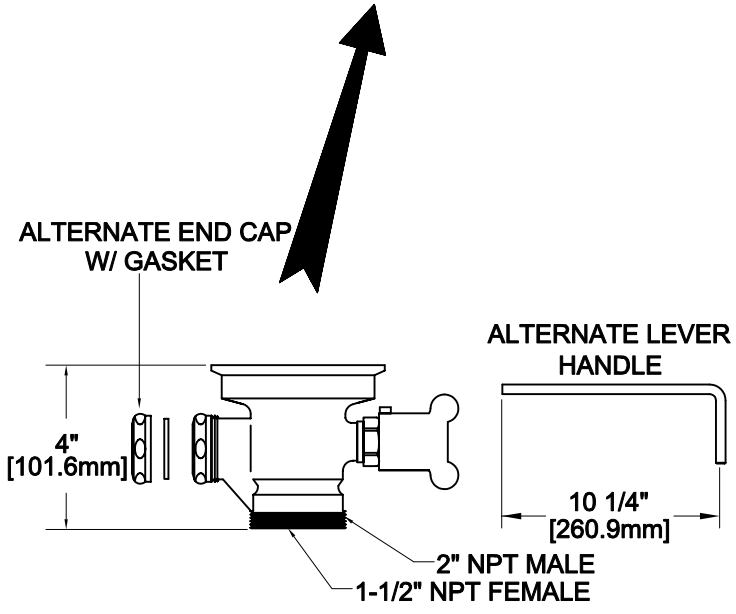
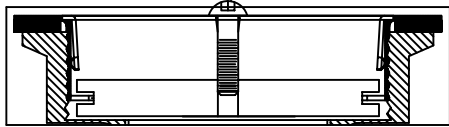

ROUGH-IN:

DRAIN:

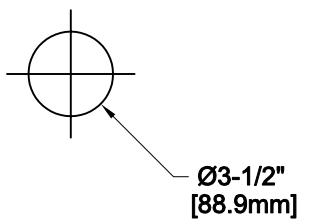

*FISHER*

FISHER MANUFACTURING COMPANY  
TOLL FREE: 800-421-6162 - FAX: 800-832-8238  
information@fisher-mfg.com - www.fisher-mfg.com