

Replacement Parts for Covered Reel Rinse Units

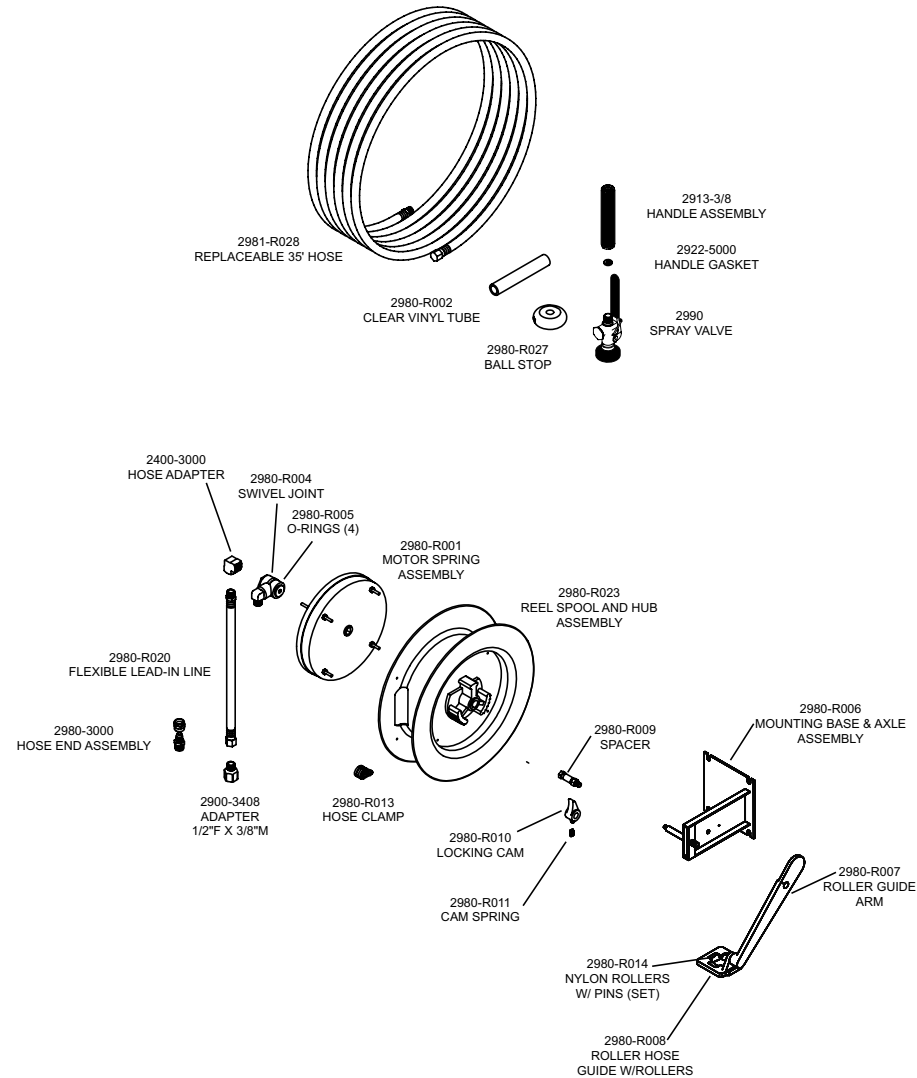

FISHER
MANUFACTURING COMPANY
PO BOX 60, TULARE, CA 93275
(800)421-6162, FAX: (800)832-8238
www.fisher-mfg.com

PART NO. 43907

REV. A

FISHER
FISHER MANUFACTURING COMPANY

Open Reel Rinse Product Installation Guide

Since 1936, Fisher Manufacturing Company has manufactured heavy-duty, high quality plumbing products and hardware specialties for the food service industry. For three generations, the Fisher family has adhered to a strict dedication of and overall value. When you install Fisher products... you install the best. Our hardware is manufactured with the standardization of internal mechanisms. All chrome plating is triple plated copper, nickel and chrome for durability. Every piece of equipment we make is rigorously tested in both our modern in-house testing center and in actual field situations under extreme conditions. Every detail is thoroughly checked. Before we make our products available to you, they pass each and every test. You get proven performance. Guaranteed.

Limited One Year Warranty

Fisher Manufacturing Company warrants its products and parts thereof (except as noted below) against defects in materials or workmanship for a period of one year after the date of original purchase. During this period Fisher Manufacturing Company will replace a defective product or part without charge to you, provided that the entire product is delivered to Fisher Manufacturing Company. All transportation and insurance charges for shipping the product to and from Fisher Manufacturing Company must be borne by you. Charges for transportation and insurance may, at the option of Fisher Manufacturing Company, be refunded depending upon our investigation of the warranty claim. This warranty does not cover external finish (except at date of original purchase) or labor costs not specifically authorized by Fisher Manufacturing Company.

A full and complete copy of our One Year limited warranty is available upon request.

WARNING:

Proposition 65 requires that we provide you with the following notice: "This product Contains A Chemical Known To The State Of California To Cause Birth Defects Or Other Reproductive Harm."



#2980 - Open Reel Rinse Unit with 35' of 3/8" ID, 3 Ply, 2 Braid Hose and Spray Valve

KEEP THIS MANUAL FOR FUTURE REFERENCE



ANSI/A112.18.1M, ANSI/NSF 61.9

FISHER MANUFACTURING COMPANY - TOLL FREE: 800-421-6162 FAX: 800-832-8238

www.fisher-mfg.com

Installation Instructions for Reel Rinse Units

WARNING! Failure to read, understand, and follow these instructions may lead to safety hazards or unsafe practices which COULD result in severe personal injury or death.

BE SURE TO CHECK WITH YOUR LOCAL DEPARTMENT HAVING JURISDICTION REGARDING BACKFLOW PREVENTION

- Installation Notes:**
- It is highly recommended that at least 2 people are involved in this installation as the hose reel is very heavy
 - Be sure water supply is shut off before beginning
 - It is recommended that any installation kit or control box is completely installed before proceeding with hose reel installation

- Items Needed for Installation:**
- (4) - 5/16" Mounting Bolts or Lag Bolts (not included)
 - (4) - Lock and Flat Washers for Bolts (not included)
 - (1) - Ratchet Socket Set (not included)
 - (1) - Crescent Wrench (not included)

Mounting Configuration Adjustment:
The hose reel assembly is provided in a wall mount configuration (shown in figure 1). If a different mounting configuration is required, such as ceiling or deck mounting, you will need to adjust the base and arm.

Secondary Support Chain:
All hose reels mounted overhead should have a secondary support chain or steel cable to protect personnel in case of structure or mounting component failure. The support chain or cable should be rated for a 300 lb. load, at minimum.

Attach one end of the secondary support chain or cable to reel. Attach the other end of the chain or cable to a structural support other than the primary mounting surface. The chain or cable should be as short as possible allowing the reel to drop no more than 6" to 12" if the primary mounting configuration fails.

- General Mounting Requirements:**
- Main shaft must be horizontal
 - When mounted overhead, add a secondary chain or cable to prevent reel from falling in case of mounting failure
 - Be sure that the roller guide is horizontal to the floor
 - See Figure 2 for proper hose reel orientation

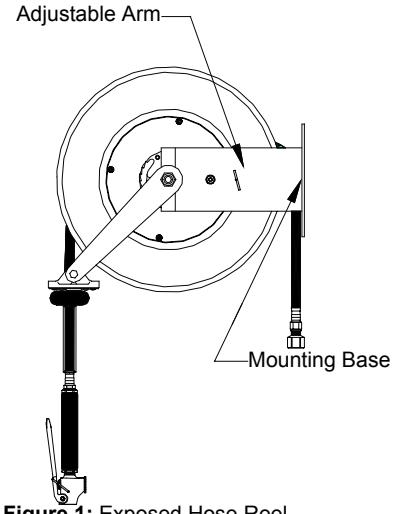

Figure 1: Exposed Hose Reel

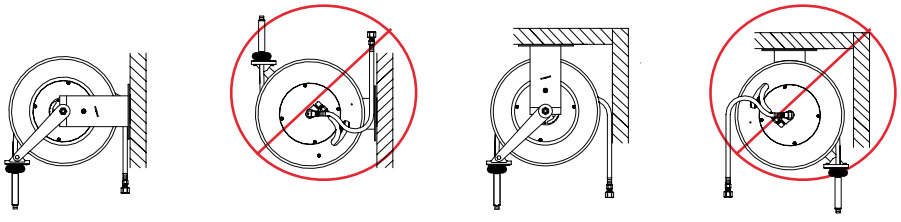

Figure 2: Correct and Incorrect Wall Mounting

Installation Instructions Continued

Mounting the Hose Reel:

- Unpack the reel and remove from wooden base.
- Using the hole pattern shown in Figure 3, mark and drill appropriate pilot holes into mounting surface.
- Mount the complete hose reel onto wall by securing and tightening all bolts and nuts.

NOTE: BE SURE MOUNTING HARDWARE DIRECTLY ENGAGES LOAD BEARING STRUCTURE

- If mounted overhead, install a secondary safety cable or chain (See: Secondary Support Chain Section).
- Connect the lead-in line to the hose reel inlet located on the left-hand side of the hose reel. Use a wrench to support the swivel while tightening the lead-in line.

NOTE: DO NOT USE A RIGID PIPE AT THE INPUT CONNECTION OF THE REEL. DOING SO WILL VOID THE PRODUCT WARRANTY

- Connect the female end of the lead-in line to the water supply. Use the included 1/2" adapter if necessary.
- Turn water supply on. Flush the system and check leaks.

Operator Instructions:

It is recommended that all personnel are properly trained on the operation of the hose reel BEFORE use.

- Turn the hose reel water supply to "ON".
- Slowly pull out the hose to the desired length. While pulling out the hose, there will be a set of 4 clicking sounds every half revolution. This is normal.

CAUTION! To avoid hose reel lockout, DO NOT over-extend the hose beyond the red band marker.

- To latch the hose reel at the desired hose length, pull the hose until you hear a clicking sound, allow the hose to retract to lock in place.
- To retract the hose reel, slowly pull the hose until you hear clicking sound. Then allow the hose to retract. Do not let go of the retracting hose. The ball stop should rest against the roller guide once the hose is completely wound back into the reel.

WARNING! DO NOT allow the hose to retract without restraining the recoil speed. NEVER let go of the hose when retracting.

- Be sure to shut off the water supply at the shut off valves when not in use for an extended period of time

CAUTION! Damage and hose failure may result if water pressure is allowed to remain in hose over extended period of time. Shut off water supply at the shut-off valves.

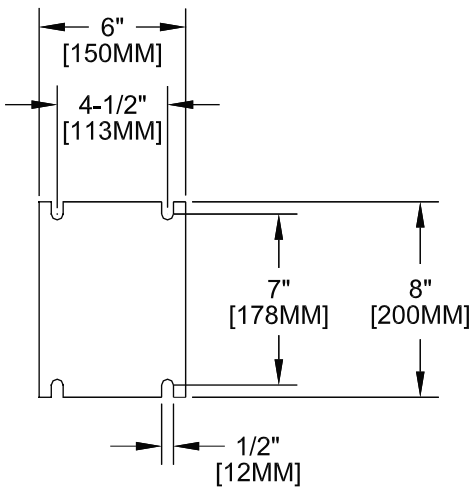

Cleaning and Maintenance Instructions

Note: To keep your Fisher Reel Rinse Unit in good working condition, periodic maintenance may be required.

FOR OPEN REEL RINSE UNITS

- Extend the hose from the reel rinse so that there is sufficient room to clean the inside of the unit. For safety reasons, it may be best to have one person extend and hold the hose while another cleans the inside of the unit.
- With the hose extended, clean the roller guides thoroughly and remove any remaining debris from the inside of the unit.
- To clean the hose, wipe it down as it is allowed to gently retract back into the reel rinse unit. Allowing it to retract as you are cleaning it will prevent the hose from becoming dirty immediately after it has been cleaned.
- Clean the spray valve and outside of the unit as necessary to preserve a clean working environment.