

APPLICATION:

JOB NAME:

QUANTITY: ITEM NO.

PRODUCT NAME:
 PRE-RINSE 8" ADJ. WALL MOUNT
 3/4" FAUCET WITH 14" ADD-ON FAUCET

_____ SPECIAL CONFIGURATION
 CHECK BASE MODEL AND OPTIONS

MODEL:
 84840 WITH WALL BRACKETS

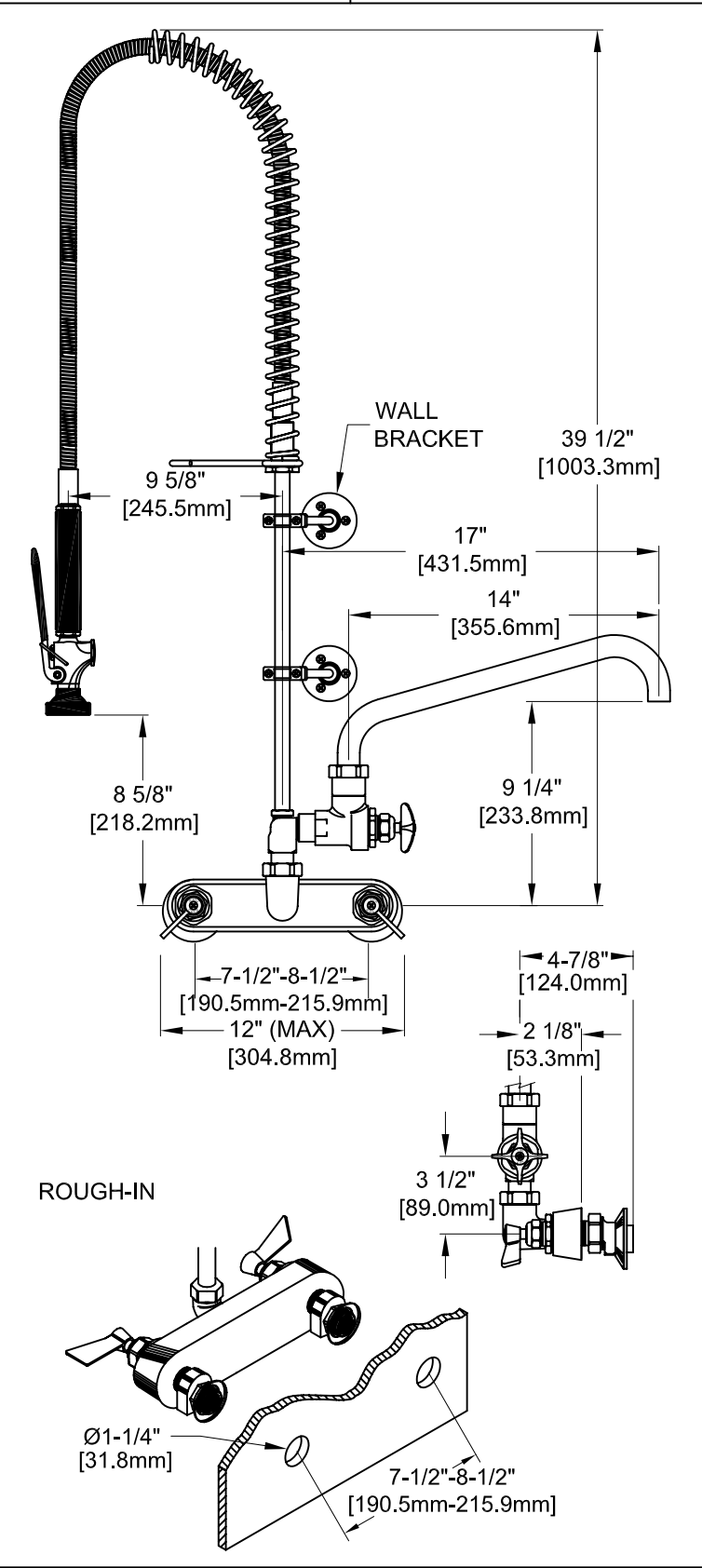

FEATURES:

3/4" MAIN CONTROL VALVE

- * 8" ADJ. WALL CONTROL FAUCET
- * 3/4" FEMALE NPT INLETS
- * SWIVELLING SEAT DISKS
- * HOT SIDE STEM - LEFT HAND
- * COLD SIDE STEM - RIGHT HAND
- * STAINLESS STEEL SEATS
- * STAINLESS STEEL SEAT SCREWS
- * STAINLESS STEEL HANDLE SCREWS

ADD-ON FAUCET

- * STEM - RIGHT HAND SWIVEL
- * COLD INDEX BUTTON
- * FULL 3/4" SEAT OPENING
- * SWIVELING SEAT DISKS
- * STAINLESS STEEL SEATS
- * STAINLESS STEEL SEAT SCREWS
- * STAINLESS STEEL HANDLE SCREWS
- * 14" SPOUT WITH 1" DIAMETER OUTLET
- * FLOW RATE: 37.0 GPM AT 80 PSI

HOSE

- * 36" LENGTH
- * STAINLESS STEEL END FITTINGS
- * STAINLESS STEEL EXTERNAL JACKET
- * 3-PLY FIBER REINFORCED INTERNAL RUBBER HOSE

ULTRA SPRAY VALVE

- * LOWEST ENERGY USER - 1.15 GPM @ 60 PSI
- * CLEANS FASTER - TEST PROVEN
- * ENGINEERED TO LAST - NO 'O' RINGS TO LEAK
- * INTERCHANGEABLE - FITS ALL BRANDS

WALL BRACKET

- * ADJUSTS FROM 2" TO 12"

SYSTEM LIMITS

- * TEMP: 40°F MIN. TO 140°F MAX.
- * PRESSURE 200 PSI MAX. STATIC

SHIPPING WEIGHT

- * 18.0 LBS

EPAct 2005 Compliant  ANSI/A112.18.1M

FISHER
 FISHER MANUFACTURING COMPANY
 TOLL FREE: 800-421-6162 - FAX: 800-832-8238
 information@fisher-mfg.com - www.fisher-mfg.com