

APPLICATION:

PRODUCT NAME: SINGLE DECK DUAL CONTROL FAUCET WITH WRIST HANDLES

JOB NAME:

SPECIAL CONFIGURATION CHECK BASE MODEL AND OPTIONS

QUANTITY:

ITEM NO.

MODEL:

- 45780 W/ 12" RIGID GOOSENECK SPOUT
- 90921 W/ 6" RIGID GOOSENECK SPOUT

OPTIONS OR MODIFICATIONS:

- SUPPLY LINES (24" OR 36") CIRCLE LENGTH
- VANDAL RESISTANT KIT
- HANDLES (CROSS OR WRIST) CIRCLE STYLE
- OTHER _____

FEATURES:

- * SINGLE DECK, DUAL CONTROL
- * SWIVELING SEAT DISKS
- * HOT SIDE STEM - RIGHT HAND
- * COLD SIDE STEM - LEFT HAND
- * STAINLESS STEEL SEATS
- * STAINLESS STEEL SEAT SCREWS
- * STAINLESS STEEL HANDLE SCREWS
- * FLEXIBLE INLET HOSES

SYSTEM LIMITS

- * TEMP: 40°F MIN. TO 140°F MAX.
- * PRESSURE 200 PSI MAX. STATIC
- * 2.20 GPM AT 80 PSI

SHIPPING WEIGHT

- * 4.5 LBS

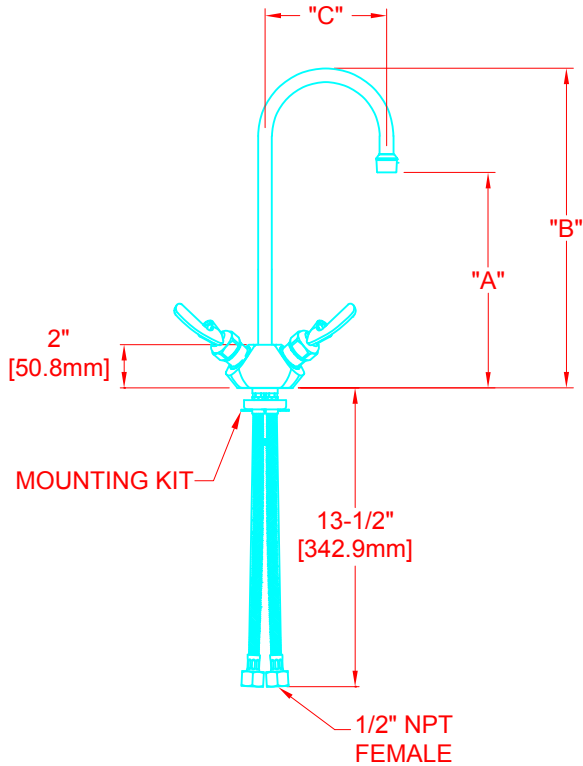

FOOTPRINT:

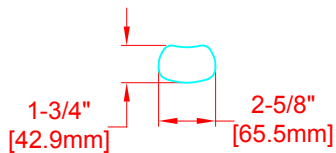

MODEL	DIM "A"	DIM "B"	DIM "C"
45780	9" [228.6mm]	13" [330.2mm]	5-1/2" [139.7mm]
90921	5" [127.0mm]	8-1/2" [215.9mm]	3-1/2" [88.9mm]

ROUGH-IN:

